

SHOW-HOW FEATURE:

BUILD YOUR OWN HOT IGNITION

first part of a three-part series

MANY different types of ignitions have been subjected to the test of tests by being adapted or converted to the engines of hot rods. Of all these, the Lincoln Zephyr 12-cylinder distributor converted for use on a V8 has proven itself to be one of the most outstanding and trouble-free conversions found in all-around competition today.

As different as the various types of distributors themselves are the conversions applied to the Zephyr distributor. Taking the "finer" points from these various types, we

come up with a durable and compact racing type ignition. All operations are well within the average craftsman's ability. The special parts necessary in the following conversion are also found in the local merchants' parts houses. All stock components like the distributors themselves may be found in local Lincoln and Mercury or Ford Agencies. Starting with the tune-up man and mechanics at these agencies and finishing at the local junkyard, more than enough parts can be accumulated to suffice.

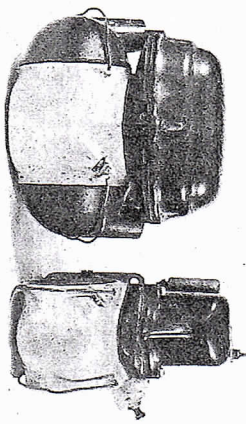

Shown here are the two stock distributors necessary for the conversion. The Lincoln distributor should, if possible, be procured complete with the coil, inner terminal plates, outer caps and a flawless distributor case. The Ford distributor may be either an 11-A (1937 to 1941 Ford) or a 40-B (1932 to 1936 Ford). Only the inner components will be used from either of these. The outer condition may be disregarded. Price on this item is from one to two dollars.

Being the same with either the 40-B or the 11-A, the saved parts are on the right with the discards on the left. Saved parts being the base, distributor cam and weight assembly with retaining ring, distributor shaft, points-plate and points-plate retaining ring or wire. If vacuum braking is to be desired, this plate may also be saved, along with its retaining ring.

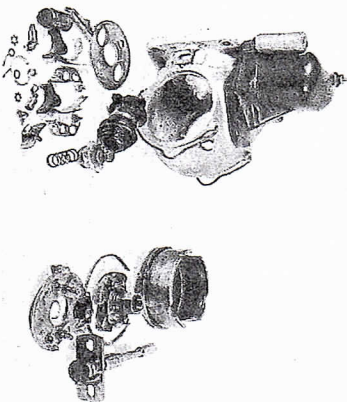

Here is the breakdown of the Lincoln Zephyr distributor, the saved parts on the left and discarded on the right. Saved parts are the case, coil, if checked and found good, inner terminal plates with outer caps, rotor, vacuum adjusting nut, cap balls, coil retaining screws and calibrated advance and retard cover plate.

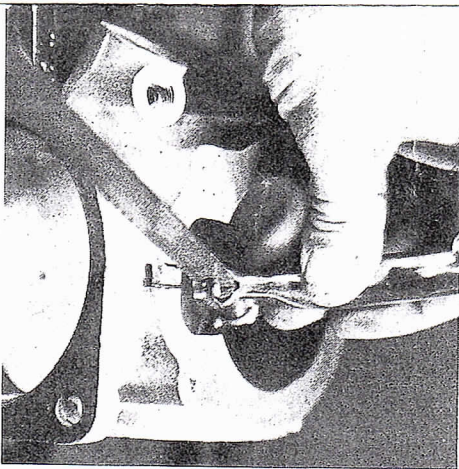

Quarter-inch wide by quarter-inch deep notch is hacksawed into case where back part of coil mounts. Slot is for new wires from condensers to points.

Opening for points-plate self-screw is widened to within 1/16" of edge of cover-boss. Exact amount can be determined by inserting Ford base with points-plate and retaining clip ring in place.

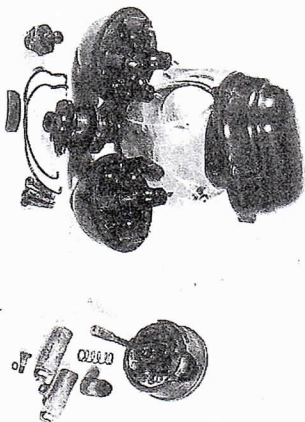
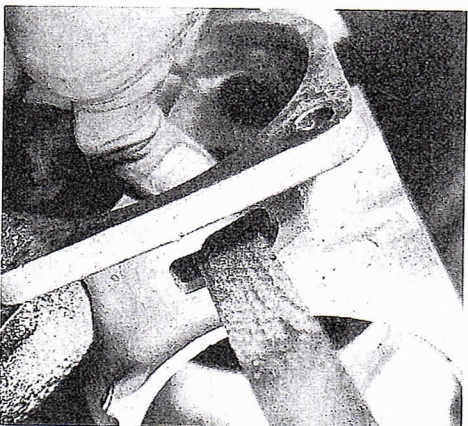

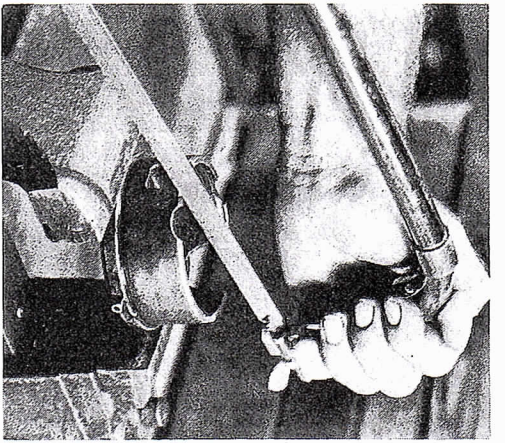

Ford base where ear of points-plate fits is lengthened by removing 1/8" with hacksaw, to allow a greater advance and retard range.

New rotor location is rough-ground on Ford distributor shaft. Note diagram #1 for exact location. Plus or minus 5 degrees is tolerable. The operation may be done completely with the use of a file.

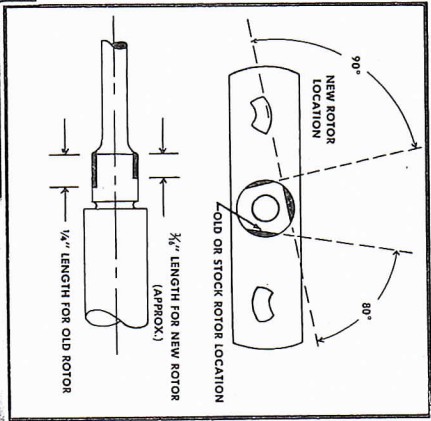

With the inserting of the Lincoln Zephyr rotor on the new rotor location, on the Ford distributor shaft and then inserting the shaft into the Ford base, insert the assembled unit into the Lincoln case.

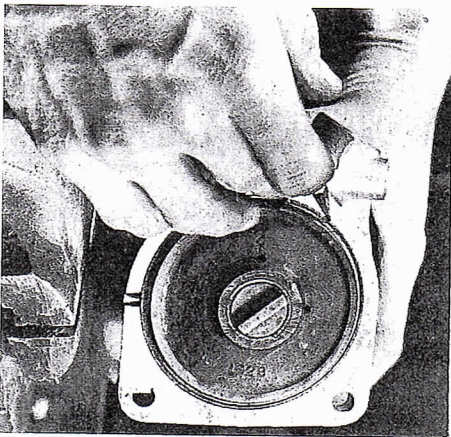

With amount to be removed determined, remove some by filing on new rotor location. Double check by assembling and disassembling a few times allowing for a minimum amount of end clearance for rotor, between .005 to .010 of an inch.

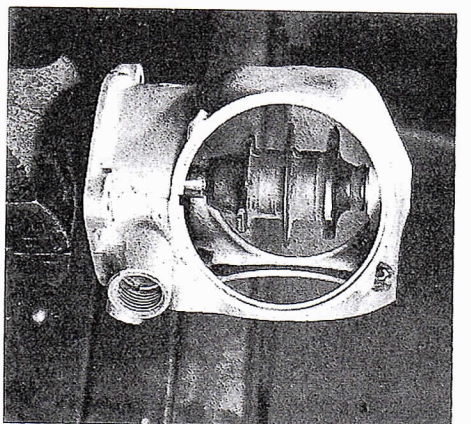

By checking to see if base is flush with case, where case mounts to timing gear cover, amount to be removed from distributor shaft where rotor mounts can be determined.

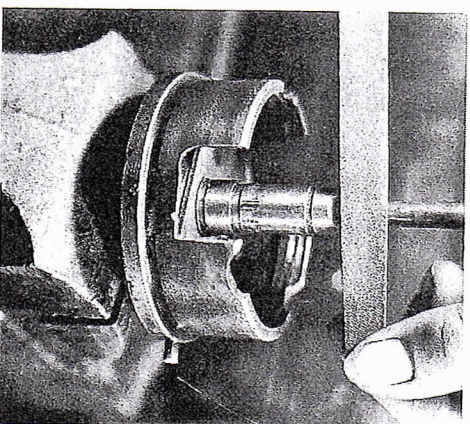

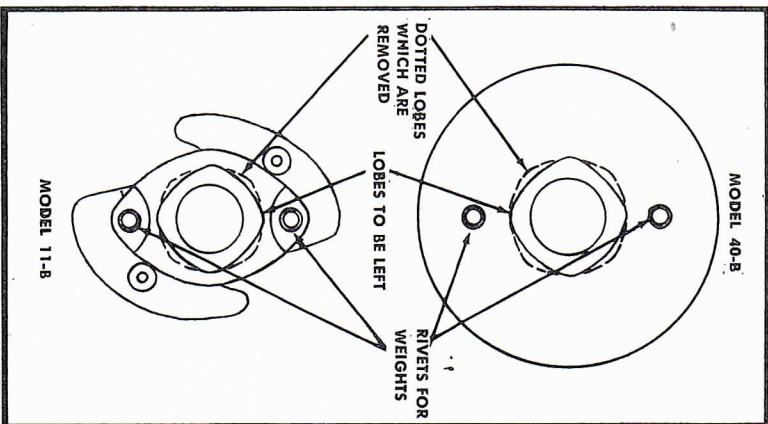

LEFT & BELOW

Since the idea of this conversion is the use of one of the coils within the Lincoln coil-housing for each bank of four cylinders instead of six, the eight-lobe Ford distributor cam must be reground to a four-lobe cam as shown in the accompanying diagram. When grinding, be sure that the lobes removed are those shown in the drawings. Also make sure that you don't cut into the lobes that are to be left. Total amount to be removed is 1/32 of an inch. Finishing touches are made with emery cloth backed up with a file.

RIGHT

New 4 lobe cam and weights may be installed in either of 2 ways with 180 degree difference. This makes no difference. Install original Ford cam and weights retaining ring. If a vacuum braking plate is desirable it may be installed unaltered at this time. The finished product will perform very nicely without this plate however.

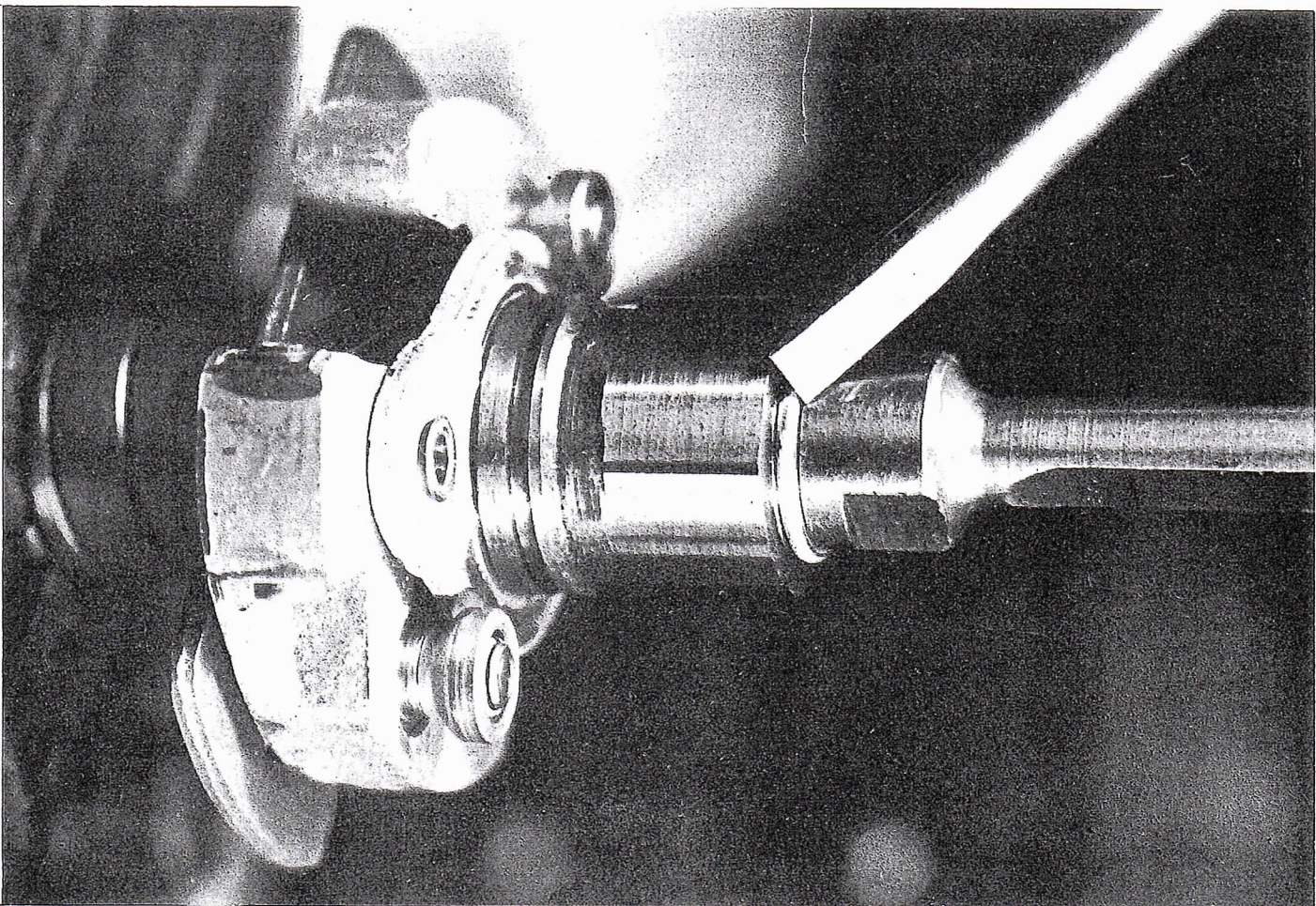
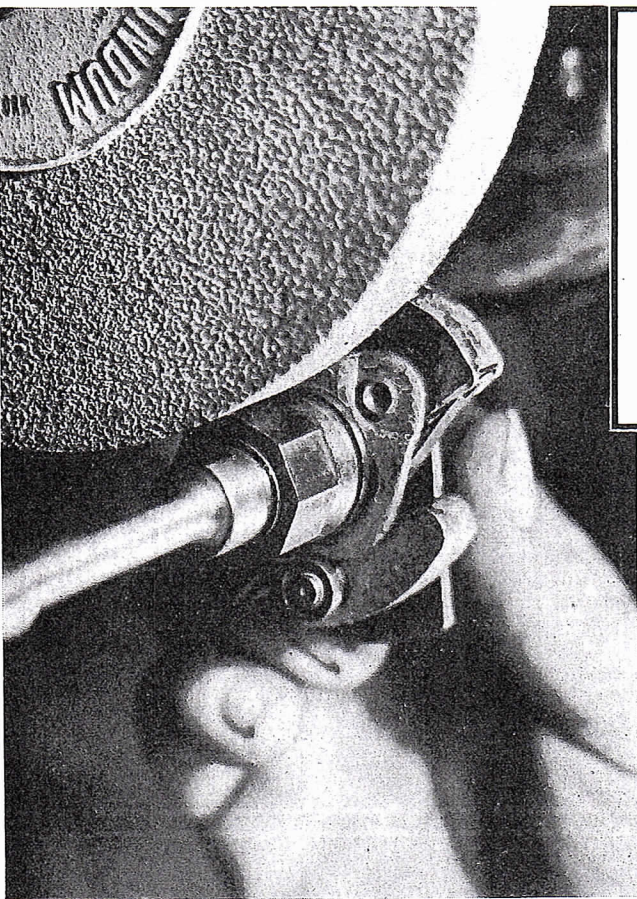

BUILD YOUR OWN



Hot Ignition

Photo Feature by Dean Moon

IN the April issue we covered the start of your Lincoln Zephyr conversion including the parts to be used and those to be discarded. We also covered the grinding of the distributor cam and the preparation of the Lincoln distributor case for the conversion. In this, the second of three installments, we will cover the conversion of the terminal plates from 12 cylinder to eight cylinder operation. The final installment next month will detail the reconstruction of the breaker plate, final assembly of the unit and tuning procedure.

Prior to converting the terminal plates, check thoroughly for cracks, missing aligning notches and carbon streaks. If plates are found to be in acceptable condition, work on same may begin. However, if there are any undesirable features about your plates, it's much cheaper in the long run to purchase new plates for the conversion, eliminating any chance of having to do the job over.

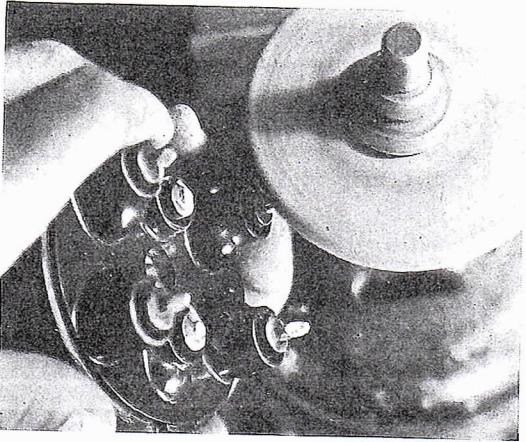

CAR CRAFT

36

Strips for converting six-wire Lincoln terminal plates to four-wire use are made from copper or brass sheet, .020-inch thick, which may be purchased at any sheet metal shop. Trim the sheet into strips 5/16-inch in width by four inches in length as shown here.

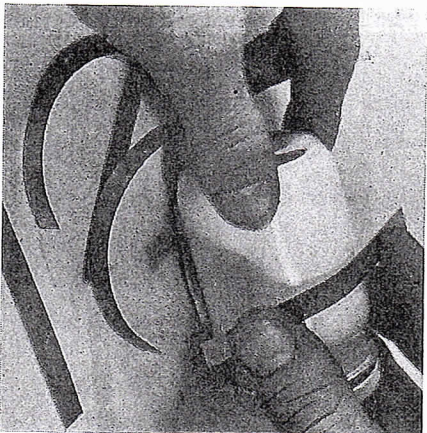

Pick-up prongs, which are brass, are given new surface by grinding wheel. This is done to all six prongs, at the same time retaining original angle or contour for rotor prongs. Remove only enough to give new surface on ends. Wire-brush the complete outer surface of pick-up prongs. This makes for better soldering surface and adhesion.

Using a good acid-core solder for cleansing effect, apply liberal amount of solder on new pick-up strips. Solder is applied on both ends for about an inch and about one inch in the center of each strip.

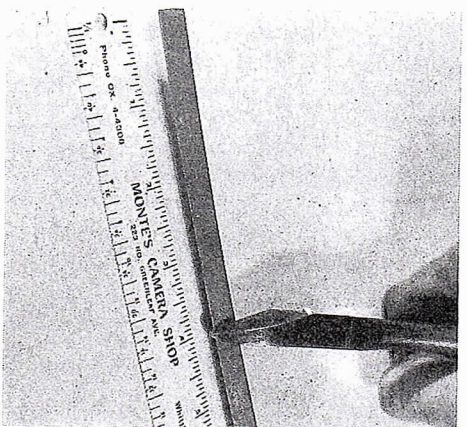

Strips are readily formed over any cylindrical object such as an oil can, glue bottle, ink bottle or what have you, which is approximately 2" in diameter. Strips will uncoil about the proper amount for the 2½-inch desired diameter.

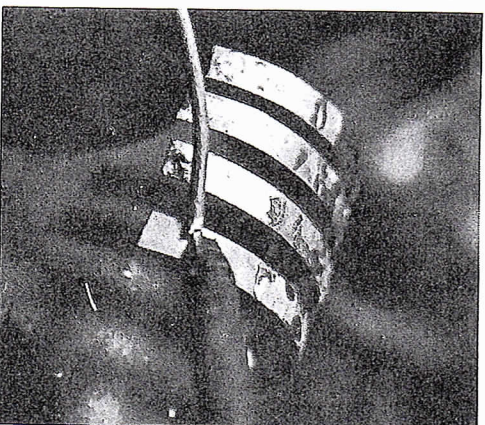

CONTINUED

MAY 1954

37

Hot Ignition

continued

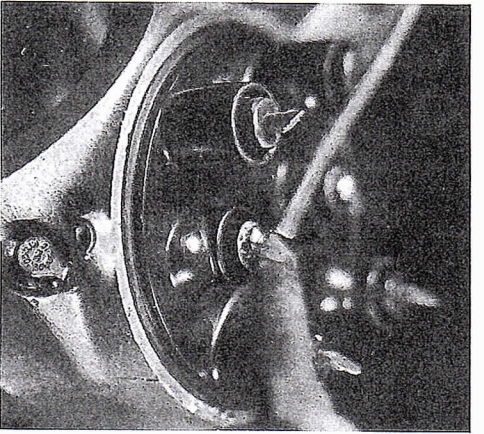

Using Lincoln Zephyr case as jig, which in turn is clamped in vise, again apply a liberal amount of solder to plate prongs. Build up about $\frac{1}{8}$ " on center or shortest prongs, avoiding prolonged contact with soldering iron. Overheating of prongs results in cracking of bakelite surrounding same.

Using glove on one hand, hold strip as shown, and apply small amount of solder on inside of strip directly above center plate prong. Aligning strip with all 3 original prongs, place soldering iron on top of strip and sweat strip to prong, again avoiding too long contact with iron. If strip at first is out of alignment, wait 'til strip, prong and plate cool before reheating and realigning.

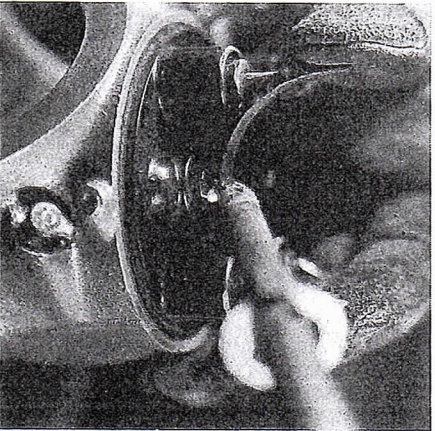

With center prongs soldered to strips, again select a cylindrical object, this time object desired should be as close as possible to $2\frac{1}{2}$ inches in diameter. Using door or similar type spring over $2\frac{1}{2}$ -inch object to hold pressure on new pick-ups, apply heat to longer prongs and tension of spring on object will force strips and prongs into close contact. An extra amount of solder may be added for strength.

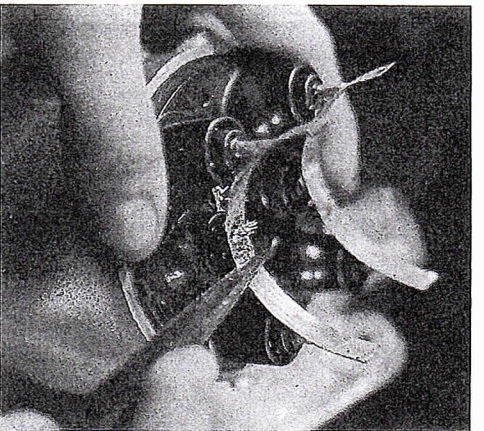

Using coarse emery cloth on same $2\frac{1}{2}$ -inch diameter object, rotate both object and cloth to remove the majority of the high spots. Finishing touches on the strips, with final polish and sanding of low spots, is administered with fine emery cloth.

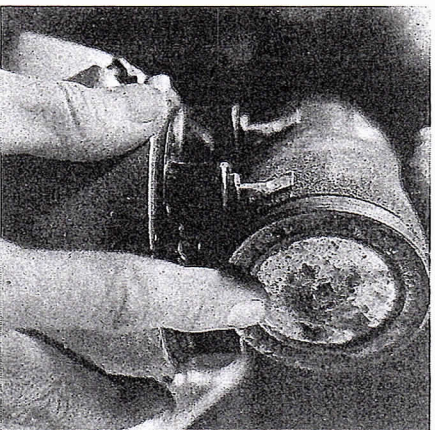

With strips now fastened on all prongs, remove excess solder from strips with bearing scraper, or sharpened three-corner file.

Excess metal at ends can now be trimmed off about $\frac{1}{4}$ -inch from where outer prongs join strips.

CONTINUED

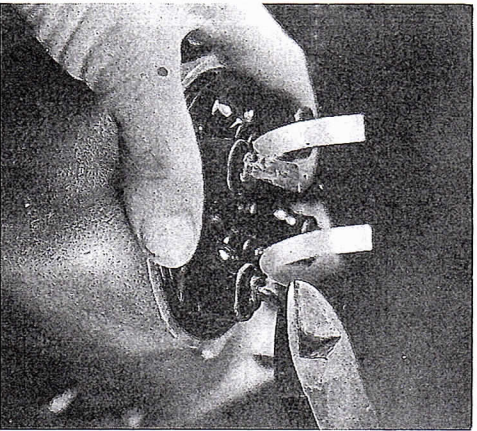
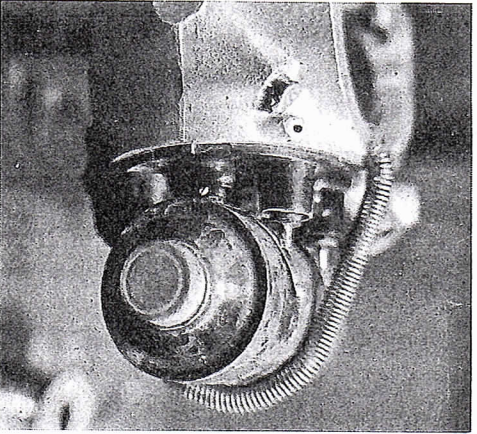

Hot Ignition continued

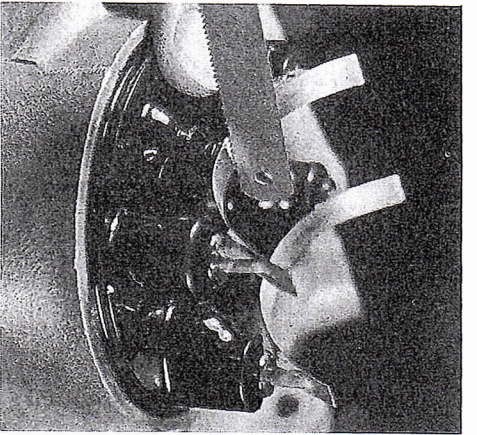

With back-saw blade, part strip just to the left of the center prong which is just beneath it. This is on the strip facing or nearest to you. Parting of both plates and all four strips is the same.

Again on strip closest to you, part strip about $\frac{1}{2}$ -inch to the left of previous cut and just to the right of left prong. Note parted strip in background.

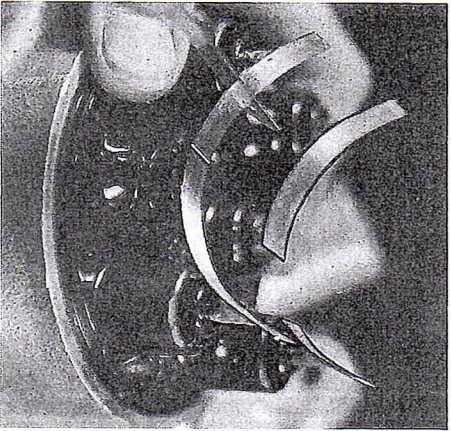

If rotor has not been previously ground, due to earlier rebuilding, grind $\frac{1}{32}$ -inch from ends of prongs. Rotor should also be checked for cracks and carbon streaks.

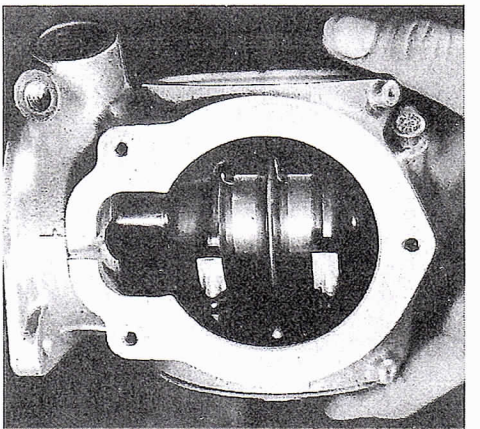

With rotor in place on distributor shaft, and shaft in base, install unit in Zephyr case. Inserting one of the newly converted terminal plates in its proper place, check rotor prong clearance, on new pick-up strips. If rotor prongs touch strips, band file enough of prong to just clear the strip. Prongs should come as close to contact with strips as possible without touching.

With rotor and plates fitted for clearance, scribe new cylinder identifying numbers and "left" and "right," on terminal plates. Whenever possible use case for fig to avoid damaging plates.

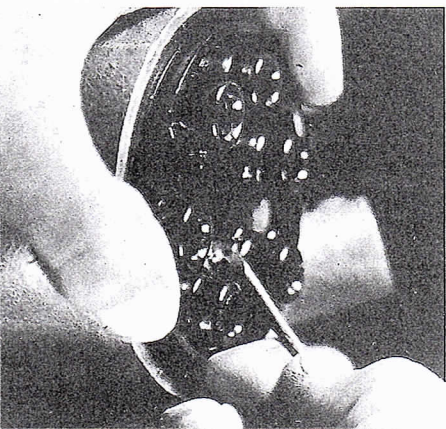

Locator notches (1, 1) are on the opposite side of plate. These must be located as shown here to differentiate right and left plates. Center terminals (2, 2) are blocked off with tape. Be sure to mark plates "Right" and "Left."

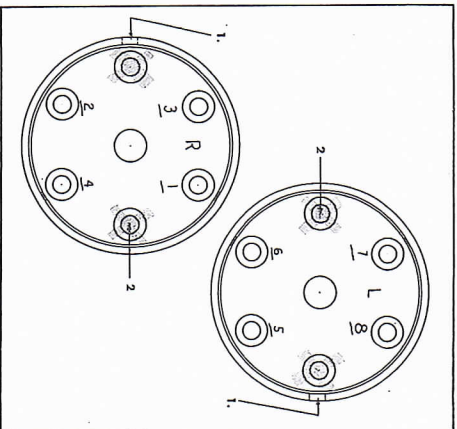
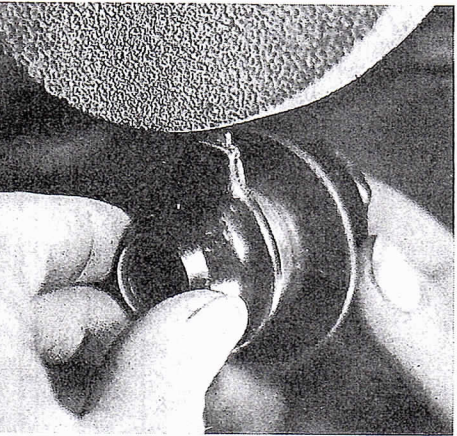

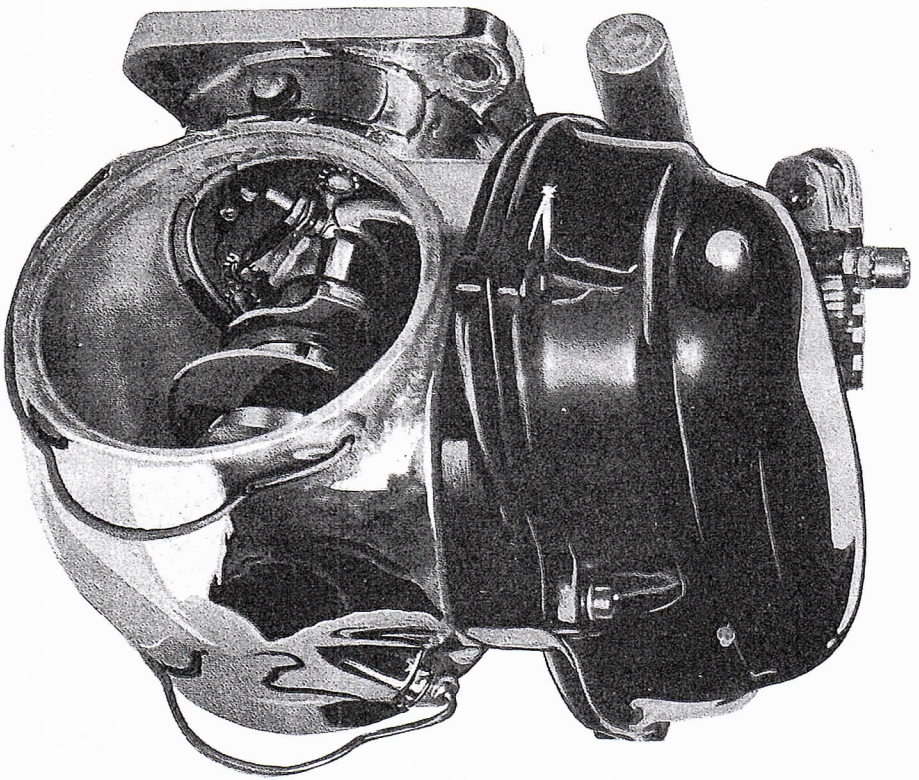

BUILD A HOT IGNITION

CONCLUSION

Breaker Plate, Synchronizing and Final Assembly

IN THE last two installments we discussed modifications to the distributor cam, case and terminal plates. With these modifications in order, you should be ready now for the final operations on the breaker plate.

In this concluding installment we cover the breaker plate, synchronizing and the final assembly of your new hot ignition. Now you can bolt the unit on the front of your engine and GO!

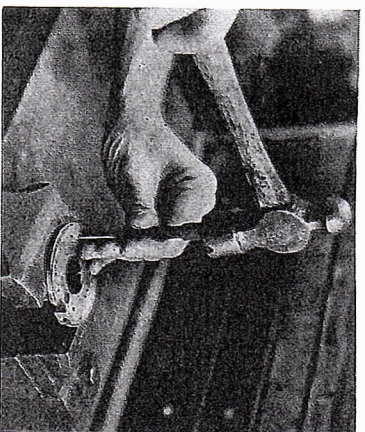

With drift punch remove the stock fulcrum pins and eccentric screws. Back the breaker plate up with the vise to prevent bending of plate.

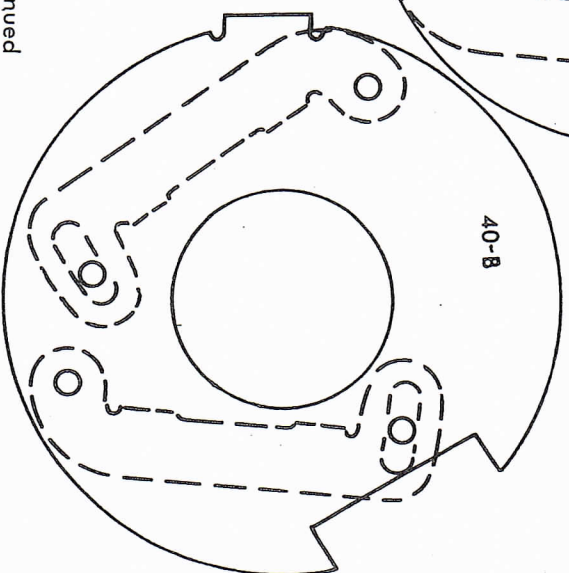
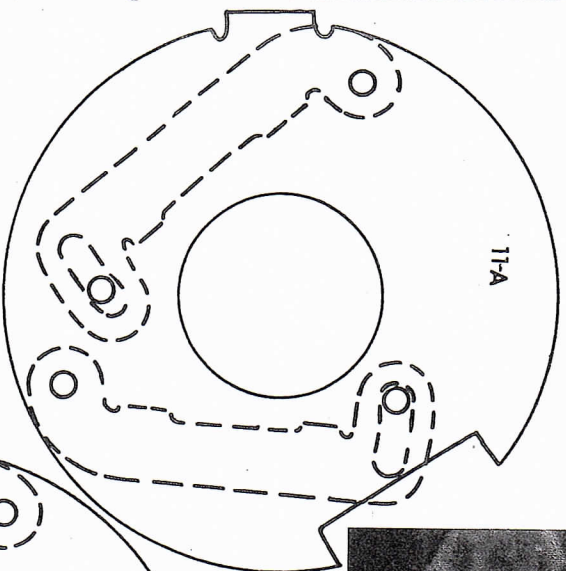
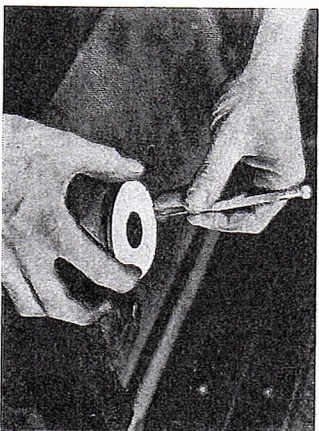

Using the proper pattern, scribe new point-set-screw locations. Be sure to use the 40-B pattern with 40-B plate and 11-A pattern for 11-A plate. Center punch at proper points. Use patterns in exact size.

continued

Hot Ignition continued

Using a #27 drill (9/64"), drill center punched locations. There are four holes to be drilled in either plate.



An 8-32 tap is used for installing new threads in newly drilled holes. When tapping is finished, chamfer tapped holes with a 1/4" drill. By using this large a drill, the rough edges of newly tapped holes can be readily removed without cutting into threads. Easy does it at this point—a touch of the drill will do the job.

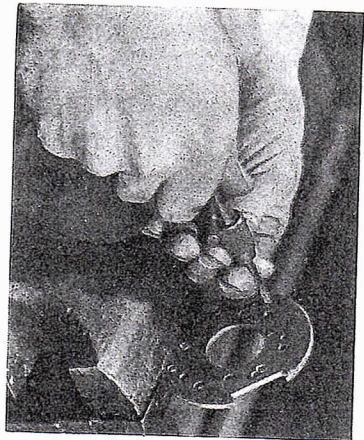

With drilling and tapping operation completed, check by holding a steel rule or similar straight-edge across the face of the plate to see if the plate is warped or uneven. File flash if uneven and polish if so desired. Install the plate in proper place in the distributor base. If a loose fit is encountered, gently bend edges of plate until a snug fit is encountered. This enables the points to retain their original settings.

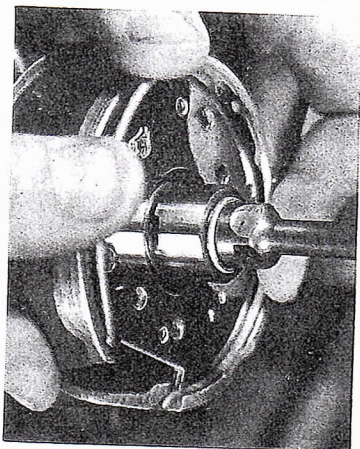

New condenser-to-magneto points wires are of 16 gauge wire cut in 2 lengths of 10" each. Terminal ends are soldered to ends of wires which will be attached to magneto points first.

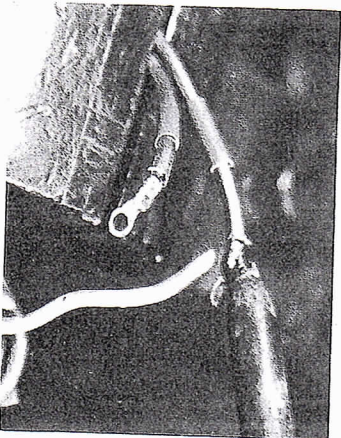

CAR CRAFT

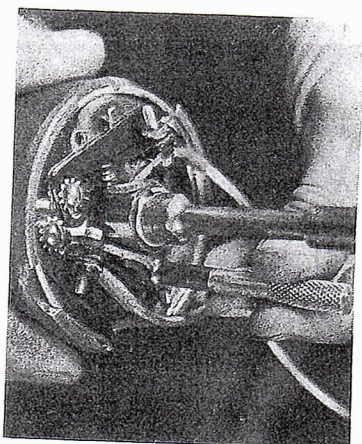

Using small rat-tail file, widen breaker plate set-screw hole in slot cover plate to within 1/16" of side on which calibrations are stamped.

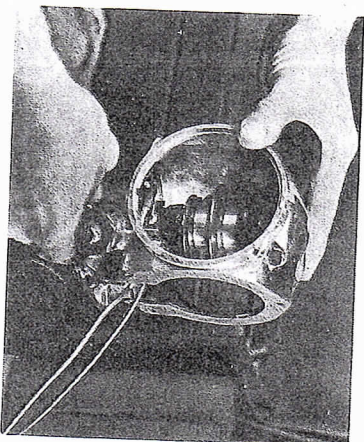

With synchronizing completed, the Lincoln-Zephyr coil, if checked and found acceptable, may now be altered to fit new distributor assembly. Remove brass springs with a pair of diagonals. These springs were originally the source of voltage for the stock Lincoln-Zephyr points. After removing springs, cover with rubber cement and place a piece of electrical rubber tape over cavities.

Points used for this conversion are available at local automotive electrical shops, garages or from parts houses. Part number for this Bendix-Scintilla magneto point (2 necessary) is 10-52344 W. Cost is \$1.75 for each set. Note in photo proper wire installation. Using shake-proof type washers, with a flat washer of approximate size on slotted end of point, install points onto points plate. Set points at .011 at this time.

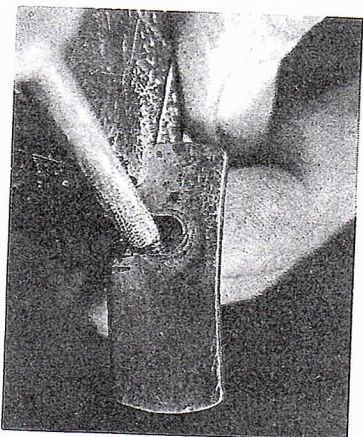

Feeding wires through case at the same time base assembly is installed, assemble unit as shown. Install breaker plate set-screw at this time. Main distributor components are now ready for synchronizing. For detailed instructions on this procedure, see end of story.

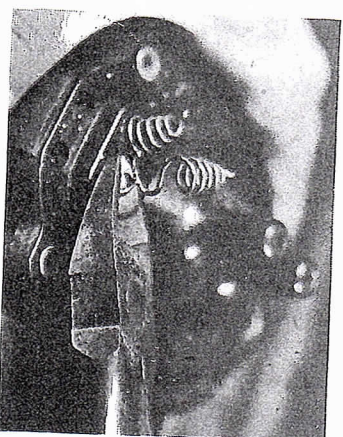

JUNE 1954

CONTINUED

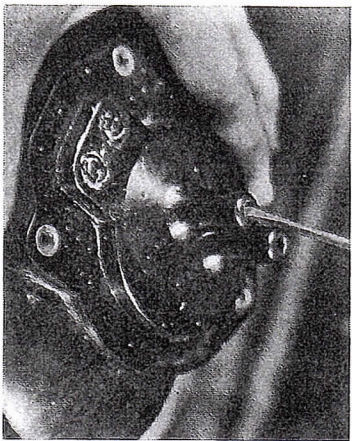

Insert small piece of sponge rubber, or weather stripping, into slot cut for points-to-condenser wires. This aids in keeping out moisture from rain, car washing, etc.

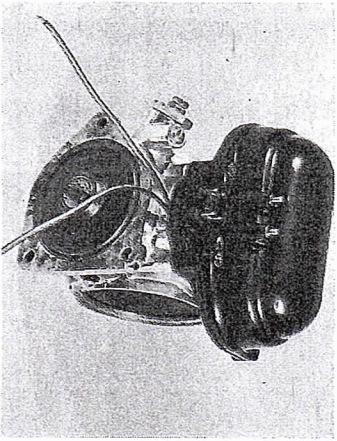

Form wires so they will fit between condensers and coil. Cut to proper length and solder wire terminal ends of appropriate size for condensers to ends of wires. Install Lincoln-Zephyr condensers with coil retaining screws firmly in place.

Hot Ignition continued

Remove any corrosion with narrow bladed screw-driver, and insert new Lincoln-Zephyr carbon brushes and springs.

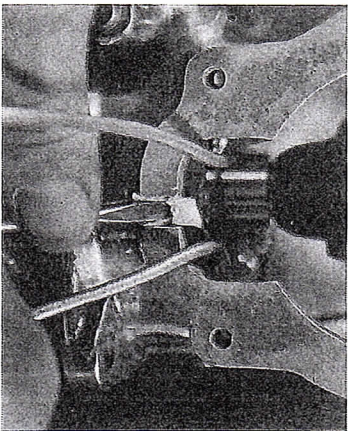

Place coil in proper location, checking to see that wires are not pinched between coil and case, also to see if carbon brushes are in proper location, and clearance for rotor is a sufficient distance from carbon brush housings.

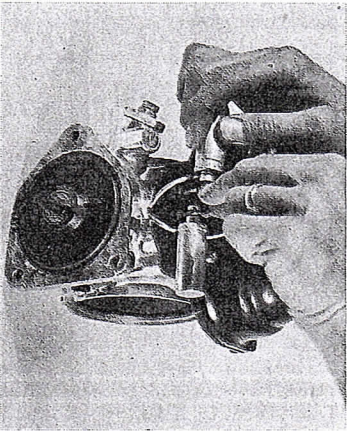

CAR CRAFT

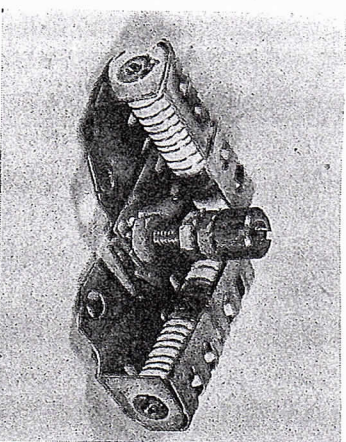

The Lincoln-Zephyr coil was manufactured for the use of resistance units, which in this case are two Ford coil resistors joined together as shown in photo to make up unit, which lets both coils get an equal amount of voltage. The main distributor lead is fastened to the center lug, which joins the resistors. Unit is fastened to coil by using two 8/32 nuts.

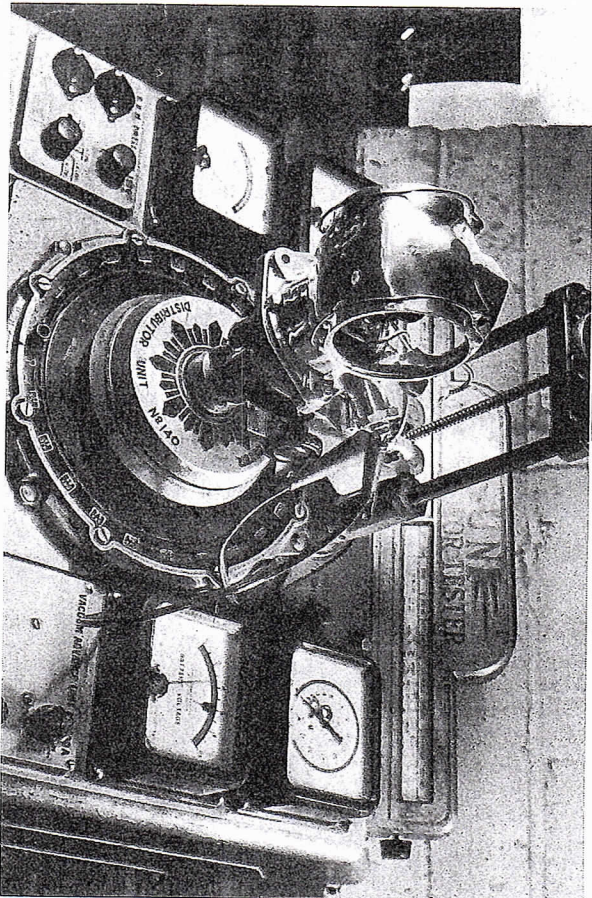

Completed distributor is now ready for the test of all tests at the local drag strip. (Note: More than one minute in LOW gear not recommended by this writer, for this test!)

SYNCHRONIZING

This type distributor is synchronized without coils attached. The operation should be done by a tune-up man who is thoroughly familiar with a stroboscope. When checking any distributor, always make sure the operating battery's voltage is within range displayed by instrument in photo, which reads Battery Voltage. Using hot lead from the strobe, which is attached to a condenser, fasten lead from the condenser to one of the protruding wires. Check for resistance, then remove lead from mentioned set of points and attach to other set and check for re-

sistance. If the points plate is snugly fit into the base, good grounding, or no resistance, should be evident. If resistance shows, check points for cleanliness and screws for tightness until cause of resistance is located and altered.

Again set points at .011 for initial setting. The converted distributor retains its left-hand rotation. With the breaker plate set screw firmly tightened, start rotating motor in left-hand rotation, and adjust distributor rpm which is half engine speed, at 250 rpm. Placing the "0" or Zero degree indicator

(Continued on page 62)

BUILD A HOT IGNITION

(Continued from page 57)

ring on the point of one of the flashes, check to see if the four flashes now registering on the degree wheel are an exact 90 degrees apart. This will show accuracy of cam. If flashes are within one degree of being 90 degrees apart, cam is acceptable. With the "0" placed at any one of the indicating flashes, switch the lead from the condenser to the other set of points. Flashes should be 45 degrees from the original set tested, and still 90 degrees apart. If flashes now indicate from 0 to 5 degrees on either side of the 45 degree mark, the point setting now being used may be altered in gap to bring flash to the exact mark. With flashes now 45 degrees apart, stop strobe rotating motor and check gap in points. If points vary only .001 to .003 in gap, but are in synchronization, initial advance may be next operation. If points vary more than this, remove one set and elongate set screw holes in the points, allowing a shifting of one set to find the proper synchronization location.

With proper synchronization of the points themselves located, and the point gaps plus or minus .001 to .003 of each other, check to see if points are still close to the desired .011 gap. Minimum point gap is .007, maximum gap being .014.

One of two settings may be made, either the initial, or maximum advance. The desired method is to adjust the strobe rotating motor to the point where the advance or centrifugal weights are at full advance which is approximately 2000 distributor rpm, depending on weights used, loosen the points plate set screw, adjust flashing arrow to the number of degrees full advance desired. For most street jobs 22 degrees full advance is satisfactory. For competition and fuel-burning machines, 24 to 28 degrees may be desirable, depending on compression ratio, etc.

If a certain amount of initial degrees are desired, adjust flashing arrow, while rotating motor is at 250 distributor rpm. Note: If slight fluctuation, or an extra flash is noticed on strobe while distributor is revved up, this is caused by a rough cam or too narrow or large point gap. It may be necessary to remove cam and polish to a smoother finish, or alter point gap.

LIL' BEEP

By Dick Doy



CAR CRAFT



WORLD FAMOUS SPEED CHAMPS & AUTO ENGINEERS REVEAL

How to Get 132 MPH!
Go 0 to 60 MPH in 8 seconds
Get 37-49 miles per gallon
Boost horsepower in 10 minutes

HERE'S THE INSIDE STORY

From the laboratories of the big oil companies: (new racing fuel mixtures . . . ways to get premium performance from regular gas . . . how to drive 15,000 miles safely without changing oil . . . dozens of other secrets)

From Watkins Glen, Bonneville, Indianapolis: (quick tune-up methods used in the pits . . . how to resurface cylinder walls without removing one part from your engine . . . winning drivers techniques . . . simple trick to get equivalent of 15 extra horsepower . . . many other tips)

From the speed shops of Southern California: (step-by-step diagrams and explanation of valve timing, cam grinding, porting, relieving, milling, filling, ram blowers . . . how one simple adjustment can increase firing power of plugs . . . everything from simple speed & power tuning to full house mills . . . how to make a water injection system for less than \$1)

From custom body builders: (simple pliers channelling, chopping, lowering; tells how to make your own Carson top)

This amazing book—the Newhouse 1953 Speed, Power and Economy Manual—is a one-volume automotive encyclopedia. The authors are active in automobile racing and design (the Newhouse Special set a 194.34 mph record in 1952 at Bonneville). Although this book is referred to by mechanics who rework stock engines to deliver 160-200 mph, it is so easy to understand that owners of ordinary cars have learned how to get more speed and power, and save up to \$275 a year. In fact, it's guaranteed to help you save 65% of repair bills . . . 80% on oil . . . 50% to get \$300 more for your car when you sell it. Everything is in non-technical language . . . pictures tell the story.

This book names products—tells how they rate under actual driving conditions. Some of the results will surprise you! Also tells how to get thousands of extra tire miles simply by "using your nose."

STOP PAYING "SUCKER PRICES" FOR MECHANICAL WORK!

Actual costs are given to help you determine fair prices. Learn tricks used by \$5-an-hour mechanics! How to repair your "fill" clutch and save \$17 . . . how to "fill" deans and save costly body work without cranking or pushing . . . even how to repair a cracked cylinder easily without removing engine.

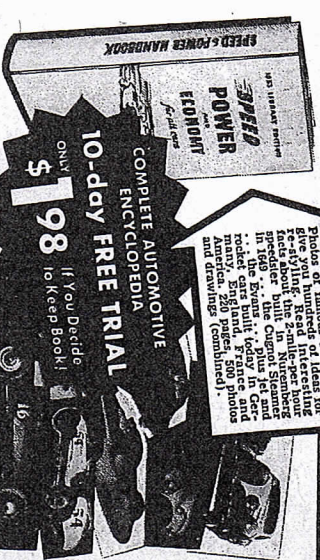

ORDER TODAY ON SPECIAL 10-DAY FREE TRIAL

Here's the deal: send for your book today and we'll include FREE with your order the 3 books described below, plus valuable Game Economy Club Membership. Read the Speed & Power Book for 10 days. If you're not convinced that this is the biggest refund and keep the other 3 books for your trouble. Mail Coupon today!

NEWHOUSE AUTOMOTIVE
5805 E. Beverly Blvd., Dept. 161
Los Angeles 22, Calif.

- WHICH OF THESE DO YOU WANT TO LEARN TO DO?**
- Boost horsepower 30%
 - Double braking power
 - Make a hill holder
 - Convert to column shift
 - Build a supercharger
 - Use jet needles
 - Stop carburetor flooding
- ALSO LEARN ABOUT:**
- Racing gear ratios
 - Fastest hot rod
 - Dual ignition
 - Anti-sway bars
 - Fiber/glas bodies
 - Upholstering

3 BOOKS FREE! These \$2.00 value books are yours to keep even if you decide to return the big Speed & Power Book: **ECONOMY DRIVING MANUAL** (75c value); **HIGH PERFORMANCE EQUIPMENT BOOK** (25c value); **150 MILES PER GALLON** (\$1 value)

SEND NO MONEY! MAIL FREE GIFT COUPON NOW!

NEWHOUSE AUTOMOTIVE, Dept. 161
5805 E. Beverly Blvd., Los Angeles 22, Calif.

Gentlemen: Without obligation, please rush me the new **SPEED AND POWER HANDBOOK** for no risk examination and trial. I agree to pay postman on arrival \$1.98 plus postage. If I am not completely satisfied I may return in 10 days for full \$1.98 back and keep the 3 handbooks for my trouble.

Name.....
Address.....
City..... Zone..... State.....
SAVE MORE! If you send \$1.98 with coupon, we pay all postal charges. Same money-back guarantee.